



EXTRA SLIM AXIAL FANS RQ





EXTRA SLIM AXIAL FANS

RQ

Main features

- Extra slim axial fans in direct current (DC) and alternated current (AC).
- Induction motor fitted with ball bearings.
- Impedence protection on models RQ 50 and RQ 160. Thermal protection on model RQ 370.
- Specially designed for fitting in electrical and electronic equipment cabinets and provide the necessary cooling where spaces for fans are minimal.
- Body made in nylon reinforced with fiberglass for DC models, die-cast aluminium for AC models.
- Impeller made in nylon reinforced with fiberglass.
- Maximum ambient temperature ranging from -10°C to +70°C.
- In accordance with the essential requirements of the 89/392/CE directive concerning machines, and with European Standards EN 292. part I and II, EN 294 and IEC 204-1 and 2.

Accessories



Filter in poliurethane with grille in polypropylene.

Model	Ref.
RQ 160	OW 643 9

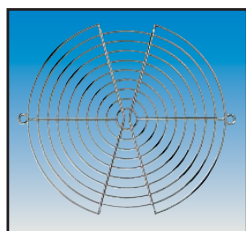

Model	Ref.
RQ 50	OW 108 3
RQ 160	OW 109 1
RQ 370	OW 642 1

Protection Grille

Safety Grille for fan protection against solid and external bodies.

Dimensions

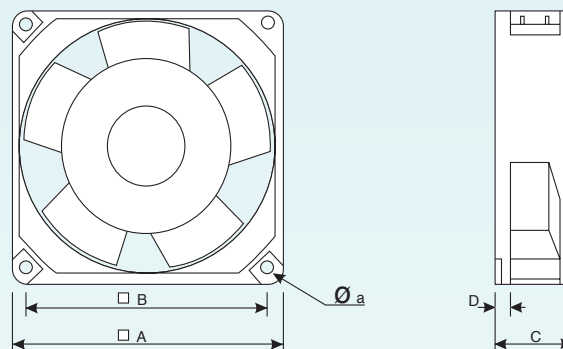

CE

Model	ø Hole	A	B	C	D	ø a	Kg
RQ 50 AC	78	80	71,4	38	3,4	4,3	0,27
RQ 50 DC	78	80	71,5	25	4	4,3	0,1
RQ 160 AC	117	119	105	38	3,2	4,3	0,55
RQ 160 DC	117	119	105	25,5	5	4,3	0,22

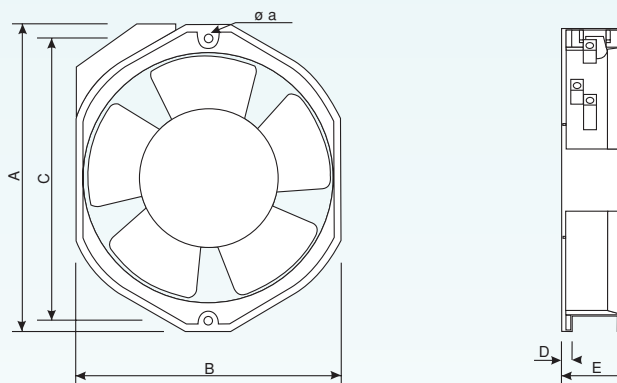

Model	ø Hole	A	B	C	D	E	ø a	Kg
RQ 370 AC	148	172	150	162	6	38	4,5	0,75

- The DC models are supplied with cables for a direct electrical connection, whilst the AC models are supplied with a terminal electrical block.

Technical Data

Model	RQ 50 DC	RQ 50 DC	RQ 160 DC	RQ 160 DC	RQ 50 AC	RQ 50 AC	RQ 160 AC	RQ 160 AC	RQ 370 AC	RQ 370 AC
Ref.	OW 585 2	OW 586 0	OW 587 8	OW 588 6	OW 404 6	OW 401 2	OW 405 3	OW 402 0	OW 589 4	OW 584 5
Supply voltage	12 V	24 V	12 V	24 V	110-120 V	220-240 V	110-120 V	220-240 V	110-120 V	220-240 V
Max Flow rate m ³ /h	60	60	184	184	45	45	138	138	318	318
Hz	-	-	-	-	50/60	50/60	50/60	50/60	50/60	50/60
W	2	2	4	4	9	10	15	15	35	35
Nom. curr. in A.	0,17	0,08	0,40	0,18	0,14	0,07	0,22	0,12	0,38	0,19
dB (A) at 2 m	26	26	33	33	31	31	34	32	52	48
rpm	3000	3000	2950	2950	2700	2700	2400	2400	2700	2700